

S-80EZA

Corner Shear Wrench

[SPECIFICATIONS]

Model	S-80EZA	
Voltage	115V	220V
Max. Current	11.5A	5.5A
Max. Power Consumption	1100W	1100W
Frequency	50 / 60Hz	
Max. Torque	804 N·m(595 lbf·ft)	
No-Load Speed	12rpm	12rpm
Weight	8.0kg(17.6 lb)	

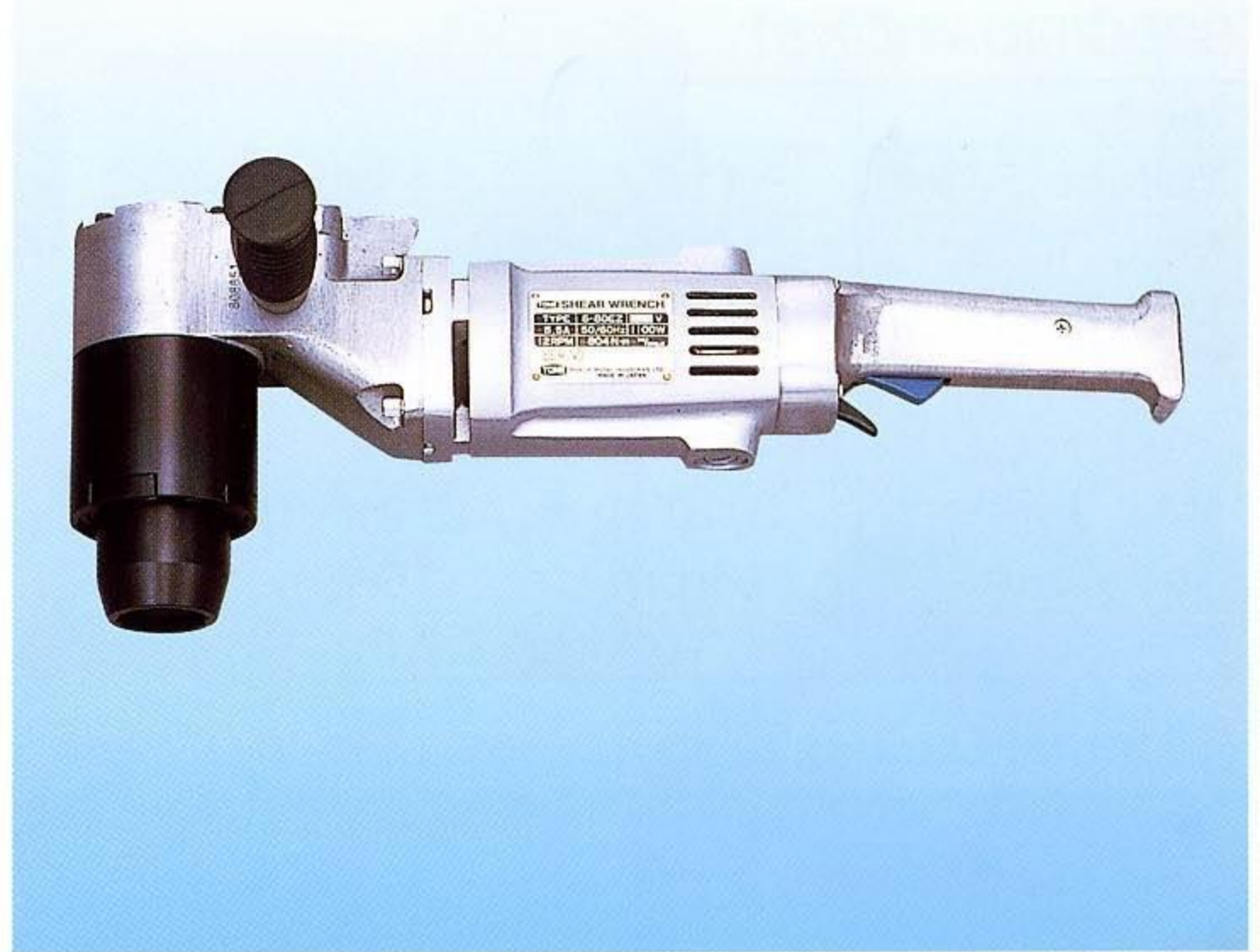

《External Dimensions》

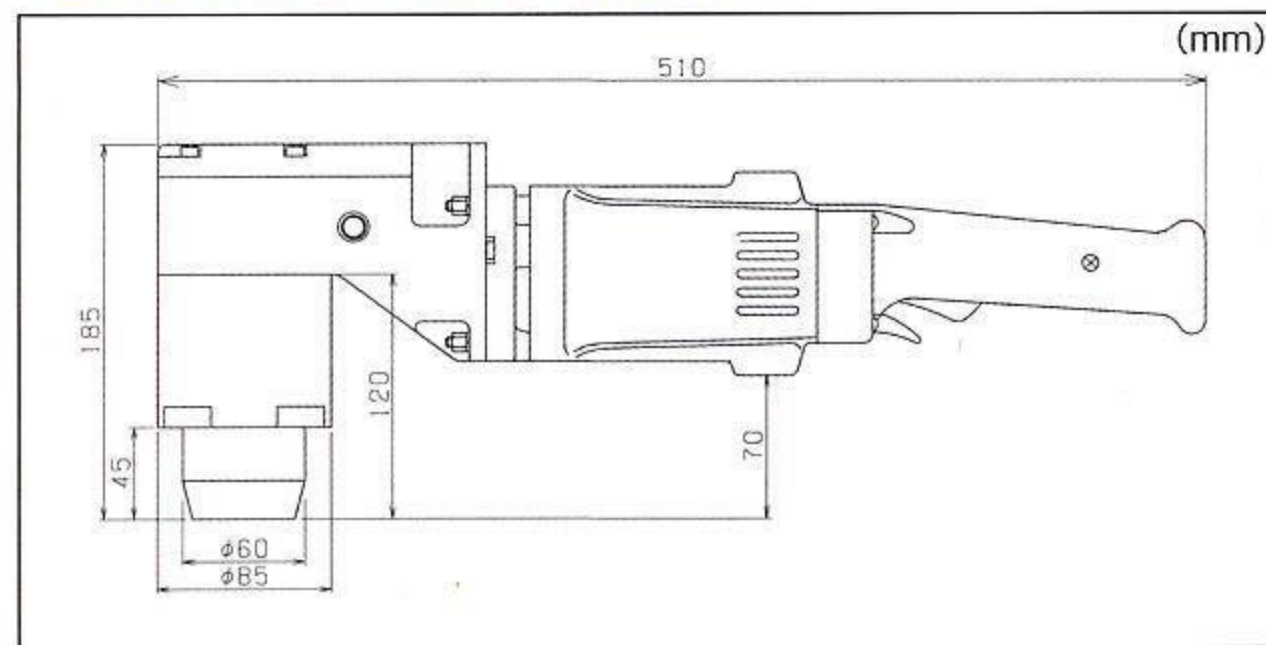

Adaptable BOLT DIA.]

M16. M20. M22
 3/4". 7/8"(1"A325 only)
 ※You can choose 1size Socket.

[ACCESSORIES]

Inner Socket	1pc.
Outer Socket	1pc.
Screw Driver	1pc.
Metal Case	1pc.

S-20HA / S-24HA

Manual Shear Wrench

Specifications & Accessories	
S-20HA	S-24HA
4.1 kg	6.3 kg
M16. M20	M22. M24
1pc. each	1pc. each



External Dimensions (mm)

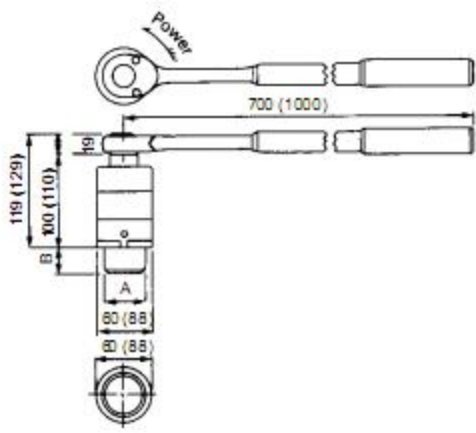

Caution on use:

S-20HA The tightening torque of this wrenches lack approximately 25%, so that to tighten it until required torque regulations.

S-24HA The tightening torque of this wrenches lack approximately 20%, so that to tighten it until required torque regulations.